



OPERATIONS MANUAL

PipeWorx MIG Gun

Manufactured for Miller Global Pipe Systems

300 Amp

Part Number: 195400

SAFETY DEPENDS ON YOU!

DO NOT INSTALL, OPERATE OR REPAIR THIS EQUIPMENT WITHOUT READING THIS OPERATING MANUAL AND THE ARC WELDING SAFETY PRECAUTIONS ON THE INSIDE FRONT COVER.

Bernard® MIG Guns are designed and built with safety in mind, but operators must follow prescribed safety guidelines.



Miller Electric Mfg. Co.

An Illinois Tool Works Company 1635 West Spencer Street Appleton, WI 54914 USA

International Headquarters-USA

USA Phone: 920-735-4504 Auto-Attended USA & Canada FAX: 920-735-4125

International FAX: 920-735-4125

European Headquarters - United Kingdom

Phone: 44 (0) 1204-593493

Fax: 44 (0) 1204-598066

MillerWelds.com

© 2023 Bernard Printed in U.S.A. DFB-OPPW-2.6

TABLE OF CONTENTS

SECTION 1 — SAFETY PRECAUTIONS — READ BEFORE USING	1
1-1 Symbol Usage	1
1-2 Arc Welding Hazards	1
1-3 California Proposition 65 Warnings	3
1-4 Principal Safety Standards	3
1-5 EMF Information	3
SECTION 2 — CONSIGNES DE SÉCURITÉ — LIRE AVANT UTILISATION	4
2-1 Symboles utilisés	4
2-2 Dangers relatifs au soudage à l'arc	4
2-3 Proposition californienne 65 avertissements	6
2-4 Principales normes de sécurité	6
2-5 Informations relatives aux CEM	6
SECTION 3 — PRECAUCIONES DE SEGURIDAD — LEA ANTES DE USAR	7
3-1 Uso de símbolos	7
3-2 Peligros en soldadura de arco	7
3-3 Advertencias de la Proposición 65 del estado de California	9
3-4 Estándares principales de seguridad	9
3-5 Información sobre los campos electromagnéticos (EMF)	9
ADDITIONAL INFORMATION	10
Introduction	10
Commercial Warranty	10
SECTION 4 — INSTALLATION	11
4-1 General Description	11
4-2 Installation	11
4-3 Helpful Operating Tips	11
SECTION 5 — MAINTENANCE AND REPAIR	13
5-1 Nozzle	13
5-2 Contact Tip	13
5-3 Gas Diffuser	13
5-4 Neck	14
5-5 Jump liner (Optional)	14
5-6 Handle	14
5-7 Cable	15
5-8 Liners	15

5-9 Rigid Strain Relief	16
5-10 Miller Power Pins	16
SECTION 6 — PARTS LIST	17
SECTION 7 — TROUBLESHOOTING	18
7-1 Troubleshooting Table	18
NOTES	20

SECTION 1 — SAFETY PRECAUTIONS — READ BEFORE USING



Protect yourself and others from injury – read, follow, and save these important safety precautions and operating instructions.

1-1 Symbol Usage



DANGER! – Indicates a hazardous situation which, if not avoided, will result in death or serious injury. The possible hazards are shown in the adjoining symbols or explained in the text.



Indicates a hazardous situation which, if not avoided, could result in death or serious injury. The possible hazards are shown in the adjoining symbols or explained in the text.

NOTICE – Indicates statements not related to personal injury.

 – Indicates special instructions.



This group of symbols means Warning! Watch Out! ELECTRIC SHOCK, MOVING PARTS, and HOT PARTS hazards. Consult symbols and related instructions below for necessary actions to avoid the hazards.

1-2 Arc Welding Hazards



The symbols shown below are used throughout this manual to call attention to and identify possible hazards. When you see the symbol, watch out, and follow the related instructions to avoid the hazard. The safety information given below is only a summary of the more complete safety information found in section 1-4 Principal Safety Standards on page 3, and in welding power source Owner's Manual. Read and follow all Safety Standards.



Only qualified persons should install, operate, maintain, and repair this equipment. A qualified person is defined as one who, by possession of a recognized degree, certificate, or professional standing, or who by extensive knowledge, training and experience, has successfully demonstrated ability to solve or resolve problems relating to the subject matter, the work, or the project and has received safety training to recognize and avoid the hazards involved.



During operation, keep everybody, especially children, away.

ELECTRIC SHOCK can kill.

- Always wear dry insulating gloves.
- Insulate yourself from work and ground.
- Do not touch live electrode or electrical parts.



- Replace worn, damaged, or cracked guns or cables.
- Turn off welding power source before changing contact tip or gun parts.
- Keep all covers and handle securely in place.

FUMES AND GASES can be hazardous.

- Keep your head out of the fumes.
- Ventilate area, or use breathing device. The recommended way to determine adequate ventilation is to sample for the composition and quantity of fumes and gases to which personnel are exposed.
- Read and understand the Safety Data Sheets (SDSs) and the manufacturer's instructions for adhesives, coatings, cleaners, consumables, coolants, degreasers, fluxes, and metals.



MOVING PARTS can injure.

- Keep away from moving parts.
- Keep away from pinch points such as drive rolls.



WELDING can cause fire or explosion.

- Do not weld near flammable material.
- Do not weld on containers that have held combustibles, or on closed containers such as tanks, drums, or pipes unless they are properly prepared according to AWS F4.1 and AWS A6.0 (see Safety Standards).
- Watch for fire; keep extinguisher nearby.
- Read and understand the Safety Data Sheets (SDSs) and the manufacturer's instructions for adhesives, coatings, cleaners, consumables, coolants, degreasers, fluxes, and metals.



BUILDUP OF GAS can injure or kill.

- Shut off compressed gas supply when not in use.
- Always ventilate confined spaces or use approved air-supplied respirator.



ARC RAYS can burn eyes and skin.

Arc rays from the welding process produce intense visible and invisible (ultraviolet and infrared) rays that can burn eyes and skin. Sparks fly off from the weld.



- Wear an approved welding helmet fitted with a proper shade of filter lenses to protect your face and eyes from arc rays and sparks when welding or watching (see ANSI Z49.1 and Z87.1 listed in Safety Standards).
- Wear approved safety glasses with side shields under your helmet.
- Use protective screens or barriers to protect others from flash, glare and sparks; warn others not to watch the arc.
- Wear body protection made from leather or flame-resistant clothing (FRC). Body protection includes oil-free clothing such as leather gloves, heavy shirt, cuffless trousers, high shoes, and a cap.

HOT PARTS can burn.

- Allow gun to cool before touching.
- Do not touch hot metal.
- Protect hot metal from contact by others.



NOISE can damage hearing.

Noise from some processes or equipment can damage hearing.



- Check for noise level limits exceeding those specified by OSHA.
- Use approved ear plugs or ear muffs if noise level is high.
- Warn others nearby about noise hazard.

WELDING WIRE can injure.

- Keep hands and body away from gun tip when trigger is pressed.



READ INSTRUCTIONS.

- Read and follow all labels and the Owner's Manual carefully before installing, operating, or servicing unit. Read the safety information at the beginning of the Manual and in each section.
- Use only genuine replacement parts from the manufacturer.
- Perform installation, maintenance, and service according to the Owner's Manuals, industry standards, and national, state, and local codes.

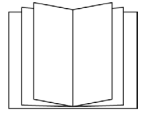

1-3 California Proposition 65 Warnings



WARNING: This product can expose you to chemicals including lead, which are known to the state of California to cause cancer and birth defects or other reproductive harm.

For more information, go to www.P65Warnings.ca.gov.

1-4 Principal Safety Standards

Safety in Welding, Cutting, and Allied Processes, American Welding Society standard ANSI Standard Z49.1. Website: www.aws.org.

Safe Practice For Occupational And Educational Eye And Face Protection, ANSI Standard Z87.1, from American National Standards Institute. Website: www.ansi.org.

Safe Practices for the Preparation of Containers and Piping for Welding and Cutting, American Welding Society Standard AWS F4.1. Website: www.aws.org.

National Electrical Code, NFPA Standard 70 from National Fire Protection Association. Website: www.nfpa.org.

Safe Handling of Compressed Gases in Cylinders, CGA Pamphlet P-1 from Compressed Gas Association. Website: www.cganet.com.

Safety in Welding, Cutting, and Allied Processes, CSA Standard W117.2 from Canadian Standards Association. Website: www.csagroup.org.

Standard for Fire Prevention During Welding, Cutting, and Other Hot Work, NFPA Standard 51B from National Fire Protection Association. Website: www.nfpa.org.

OSHA, Occupational Safety and Health Standards for General Industry, Title 29, Code of Federal Regulations (CFR), Part 1910.177 Subpart N, Part 1910 Subpart Q, and Part 1926, Subpart J. Website: www.osha.gov.

SR7 2022-01

1-5 EMF Information

Electric current flowing through any conductor causes localized electric and magnetic fields (EMF). The current from arc welding (and allied processes including spot welding, gouging, plasma arc cutting, and induction heating operations) creates an EMF field around the welding circuit. EMF fields may interfere with some medical implants, e.g. Pacemakers. Protective measures for persons wearing medical implants have to be taken. For example, restrict access for passersby or conduct individual risk assessment for welders. All welders should use the following procedures in order to minimize exposure to EMF fields from the welding circuit:

1. Keep cables close together by twisting or taping them, or using a cable cover.
2. Do not place your body between welding cables. Arrange cables to one side and away from the operator.

3. Do not coil or drape cables around your body.
4. Keep head and trunk as far away from the equipment in the welding circuit as possible.
5. Connect work clamp to workpiece as close to the weld as possible.
6. Do not work next to, sit or lean on the welding power source.
7. Do not weld whilst carrying the welding power source wire feeder.

About Implanted Medical Devices:

Implanted Medical Device wearers should consult their doctor and the device manufacturer before performing or going near arc welding, spot welding, gouging, plasma arc cutting, or induction heating operations. If cleared by your doctor, then following the above procedures is recommended.

SECTION 2 — CONSIGNES DE SÉCURITÉ — LIRE AVANT UTILISATION

 Pour écarter les risques de blessure pour vous-même et pour autrui — lire, appliquer et ranger en lieu sûr ces consignes relatives aux précautions de sécurité et au mode opératoire.

2-1 Symboles utilisés

 **DANGER!** – Indique une situation dangereuse qui si on l'évite pas peut donner la mort ou des blessures graves. Les dangers possibles sont montrés par les symboles joints ou sont expliqués dans le texte.

 Indique une situation dangereuse qui si on l'évite pas peut donner la mort ou des blessures graves. Les dangers possibles sont montrés par les symboles joints ou sont expliqués dans le texte.

AVIS – Indique des déclarations pas en relation avec des blessures personnelles.

 – Indique des instructions spécifiques.



Ce groupe de symboles veut dire Avertissement! Attention! DANGER DE CHOC ELECTRIQUE, PIECES EN MOUVEMENT, et PIECES CHAUDES. Reportez-vous aux symboles et aux directives cidessous afin de connaître les mesures à prendre pour éviter tout danger.

2-2 Dangers relatifs au soudage à l'arc

 Les symboles donnés ci-après sont utilisés dans tout le manuel pour attirer l'attention sur les dangers possibles et pour indiquer le type de danger dont il s'agit. Quand on voit le symbole, prendre garde et suivre les directives correspondantes pour éviter le danger. Les consignes de sécurité présentées ci-après ne font que résumer l'information contenue dans les Normes de sécurité principales, et dans le Guide d'utilisation de la source de courant de soudage. Lire et suivre toutes les Normes de sécurité.

 L'installation, l'utilisation, l'entretien et les réparations ne doivent être confiés qu'à des personnes qualifiées. Une personne qualifiée est définie comme celle qui, par la possession d'un diplôme reconnu, d'un certificat ou d'un statut professionnel, ou qui, par une connaissance, une formation et une expérience approfondies, a démontré avec succès sa capacité à résoudre les problèmes liés à la tâche, le travail ou le projet et a reçu une formation en sécurité afin de reconnaître et d'éviter les risques inhérents.

 Au cours de l'utilisation, tenir toute personne à l'écart et plus particulièrement les enfants.

UN CHOC ÉLECTRIQUE peut tuer.



- Porter toujours des gants secs et isolants.
- S'isoler de la pièce et de la terre.
- Ne jamais toucher une électrode ou des pièces électriques sous tension.
- Remplacer les pistolets ou câbles de soudage qui sont endommagés, usés ou craquelés.
- Mettre la soudeuse hors tension avant de remplacer un bec contact ou des pièces de pistolet.
- S'assurer que tous les couvercles et poignées sont fermement assujettis.

LES FUMÉES ET LES GAZ peuvent être dangereux.



- Garder la tête hors des fumées.
- Aérer la zone de travail ou porter un appareil respiratoire. Pour déterminer la bonne ventilation, il est recommandé de procéder à un prélèvement pour la composition et la quantité de fumées et de gaz auxquels est exposé le personnel.
- Lire et comprendre les fiches de données de sécurité et les instructions du fabricant concernant les adhésifs, les revêtements, les nettoyeurs, les consommables, les produits de refroidissement, les dégraissants, les flux et les métaux.

Les PIÈCES MOBILES peuvent causer des blessures.



- Ne pas s'approcher des organes mobiles.
- Ne pas s'approcher des points de coincement tels que des rouleaux de commande.

Le SOUDAGE peut provoquer un incendie ou une explosion.



- Ne pas souder à proximité de matériaux inflammables
- Ne pas effectuer le soudage sur des conteneurs fermés tels que des réservoirs, tambours, ou conduites, à moins qu'ils n'aient été préparés correctement conformément à AWS F4.1 et AWS A6.0 (voir les Normes de Sécurité).
- Prendre garde aux incendies et toujours avoir un extincteur à proximité.

- Lire et comprendre les fiches de données de sécurité et les instructions du fabricant concernant les adhésifs, les revêtements, les nettoyeurs, les consommables, les produits de refroidissement, les dégraisseurs, les flux et les métaux.

L'ACCUMULATION DE GAZ risquent de provoquer des blessures ou même la mort.



- Fermer l'alimentation du gaz comprimé en cas de non utilisation.
- Veiller toujours à bien aérer les espaces confinés ou se servir d'un respirateur d'adduction d'air homologué.

LE RAYONNEMENT DE L'ARC peut brûler les yeux et la peau.



Le rayonnement de l'arc du procédé de soudage génère des rayons visibles et invisibles intenses (ultraviolets et infrarouges) susceptibles de provoquer des brûlures dans les yeux et sur la peau. Des étincelles sont projetées pendant le soudage.

- Porter un casque de soudage approuvé muni de verres filtrants approprié pour protéger visage et yeux pendant le soudage (voir ANSI Z49.1 et Z87.1 énuméré dans les normes de sécurité).
- Porter des lunettes de sécurité avec écrans latéraux même sous votre casque.
- Avoir recours à des écrans protecteurs ou à des rideaux pour protéger les autres contre les rayonnements les éblouissements et les étincelles ; prévenir toute personne sur les lieux de ne pas regarder l'arc.
- Porter une protection corporelle en cuir ou des vêtements ignifuges (FRC). La protection du corps comporte des vêtements sans huile, comme des gants de cuir, une chemise solide, des pantalons sans revers, des chaussures hautes et une casquette.

LES PIÈCES CHAUDES peuvent provoquer des brûlures.



- Laisser refroidir le pistolet avant de le toucher.
- Ne pas toucher d'objets métalliques chauds.
- Abriter les objets métalliques contre tout contact par les personnes à proximité.

Le BRUIT peut endommager l'ouïe.

Le bruit des processus et des équipements peut affecter l'ouïe.



- Vérifier si les niveaux de bruit excèdent les limites spécifiées par l'OSHA.
- Utiliser des bouche-oreilles ou des serre-tête antibruit approuvés si le niveau de bruit est élevé.

- Avertir les personnes à proximité au sujet du danger inhérent au bruit.

LES FILS DE SOUDAGE peuvent provoquer des blessures.



- Éloigner les mains et le corps de la buse du pistolet après avoir appuyé sur la gâchette.

LIRE LES INSTRUCTIONS.

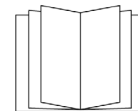

- Lire et appliquer les instructions sur les étiquettes et le Mode d'emploi avant l'installation, l'utilisation ou l'entretien de l'appareil. Lire les informations de sécurité au début du manuel et dans chaque section.
- N'utiliser que les pièces de remplacement provenant du fabricant.
- Effectuer l'installation, l'entretien et toute intervention selon les manuels d'utilisateurs, les normes nationales, provinciales et de l'industrie, ainsi que les codes municipaux.

2-3 Proposition californienne 65 avertissements



AVERTISSEMENT – Ce produit peut vous exposer à des produits chimiques tels que le plomb, reconnu par l'État de Californie comme cancérigènes et sources de malformations ou d'autres troubles de la reproduction

Pour plus d'informations, consulter www.P65Warnings.ca.gov.

2-4 Principales normes de sécurité

Safety in Welding, Cutting, and Allied Processes, American Welding Society standard ANSI Standard Z49.1. Website: www.aws.org.

Safe Practice For Occupational And Educational Eye And Face Protection, ANSI Standard Z87.1, from American National Standards Institute. Website: www.ansi.org.

Safe Practices for the Preparation of Containers and Piping for Welding and Cutting, American Welding Society Standard AWS F4.1 from Global Engineering Documents. Website: www.aws.org.

National Electrical Code, NFPA Standard 70 from National Fire Protection Association. Website: www.nfpa.org.

Safe Handling of Compressed Gases in Cylinders, CGA Pamphlet P-1 from Compressed Gas Association. Website: www.cganet.com.

Safety in Welding, Cutting, and Allied Processes, CSA Standard W117.2 from Canadian Standards Association. Website: www.csagroup.org.

Standard for Fire Prevention During Welding, Cutting, and Other Hot Work, NFPA Standard 51B from National Fire Protection Association. Website: www.nfpa.org.

OSHA, Occupational Safety and Health Standards for General Industry, Title 29, Code of Federal Regulations (CFR), Part 1910.177 Subpart N, Part 1910 Subpart Q, and Part 1926, Subpart J. Website: www.osha.gov.

SR7_fre 2022-01

2-5 Informations relatives aux CEM

Le courant électrique qui traverse tout conducteur génère des champs électromagnétiques (CEM) à certains endroits. Le courant issu d'un soudage à l'arc (et de procédés connexes, y compris le soudage par points, le gougeage, le découpage plasma et les opérations de chauffage par induction) crée un champ électromagnétique (CEM) autour du circuit de soudage. Les champs électromagnétiques produits peuvent causer interférence à certains implants médicaux, p. ex. les stimulateurs cardiaques. Des mesures de protection pour les porteurs d'implants médicaux doivent être prises: par exemple, des restrictions d'accès pour les passants ou une évaluation individuelle des risques pour les soudeurs. Tous les soudeurs doivent appliquer les procédures suivantes pour minimiser l'exposition aux CEM provenant du circuit de soudage:

1. Rassembler les câbles en les torsadant ou en les attachant avec du ruban adhésif ou avec une housse.
2. Ne pas se tenir au milieu des câbles de soudage. Disposer les câbles d'un côté et à distance de l'opérateur.

3. Ne pas courber et ne pas entourer les câbles autour de votre corps.
4. Maintenir la tête et le torse aussi loin que possible du matériel du circuit de soudage.
5. Connecter la pince sur la pièce aussi près que possible de la soudure.
6. Ne pas travailler à proximité d'une source de soudage, ni s'asseoir ou se pencher dessus.
7. Ne pas souder tout en portant la source de soudage ou le dévidoir.

En ce qui concerne les implants médicaux :

Les porteurs d'implants doivent d'abord consulter leur médecin avant de s'approcher des opérations de soudage à l'arc, de soudage par points, de gougeage, du coupage plasma ou de chauffage par induction. Si le médecin approuve, il est recommandé de suivre les procédures précédentes.

SECTION 3 — PRECAUCIONES DE SEGURIDAD — LEA ANTES DE USAR



Protéjase usted mismo y a otros contra lesiones — lea, cumpla y conserve estas importantes precauciones de seguridad e instrucciones de utilización.

3-1 Uso de símbolos



PELIGRO! – Indica una situación peligrosa que, si no se la evita, resultará en muerte o lesión grave. Los peligros posibles se muestran en los símbolos adjuntos o se explican en el texto.



Indica una situación peligrosa que, si no se la evita, podría resultar en muerte o lesión grave. Los peligros posibles se muestran en los símbolos adjuntos, o se explican en el texto.

AVISO – Indica precauciones no relacionadas a lesiones personales.

 – Indica instrucciones especiales.



Este grupo de símbolos significa ¡Advertencia!, ¡Cuidado! **CHOQUE O DESCARGA ELÉCTRICA, PIEZAS QUE SE MUEVEN, y peligros de PARTES CALIENTES.** Consulte los símbolos y las instrucciones relacionadas que aparecen a continuación para ver las acciones necesarias para evitar estos peligros.

3-2 Peligros en soldadura de arco



Los símbolos mostrados abajo se usan en todo este manual para llamar la atención e identificar los posibles peligros. Cuando vea el símbolo, preste atención y siga las instrucciones relacionadas para evitar el peligro. La información de seguridad dada abajo es solamente un resumen de la información más completa de seguridad que se encuentra en los estándares de seguridad, y la fuente de alimentación para soldadura del Manual del usuario. Lea y siga todas las normas de seguridad.



Solamente personal cualificado debe instalar, utilizar, mantener y reparar este equipo. La definición de personal cualificado es cualquier persona que, debido a que posee un título, un certificado o una posición profesional reconocida, o gracias a su gran conocimiento, capacitación y experiencia, haya demostrado con éxito la capacidad para solucionar o resolver problemas relacionados con el trabajo, el proyecto o el tema en cuestión, además de haber asistido a una capacitación en seguridad para reconocer y evitar los peligros que implica el proceso.



Durante su operación mantenga lejos a todos, especialmente a los niños.

UNA DESCARGA ELÉCTRICA puede matarlo.



- Siempre use guantes aislantes secos.
- Aíslese usted mismo del trabajo y la tierra.
- No toque electrodo eléctricamente vivo o partes eléctricamente vivas.
- Reemplace antorchas o cables desgastados, dañados o rotos.
- Repare o reemplace aislamiento de la pistola o del cable que esté desgastado, dañado o agrietado.
- Apague la máquina de soldar antes de cambiar los tubos de contacto o piezas de la antorcha.
- Mantenga todas las tapas y asa bien seguras en sitio.

HUMO y GASES pueden ser peligrosos.



- Mantenga su cabeza fuera del humo.
- Ventile el lugar o use un aparato para respirar. El método recomendado para determinar la ventilación adecuada es tomar muestras de la composición y cantidad de humos y gases a los que está expuesto el personal.
- Lea y entienda las Hojas de datos del material (SDS) y las instrucciones del fabricante relacionadas con los adhesivos, metales, consumibles, recubrimientos, limpiadores, refrigerantes, desengrasadores, fundentes y metales.

Las PIEZAS MÓVILES pueden provocar lesiones.



- Aléjese de toda parte en movimiento.
- Aléjese de todo punto que pellizque, tal como rodillos impulsados.

EL SOLDAR puede causar fuego o explosión.



- No suelde cerca de material inflamable
- No suelde en recipientes que han contenido combustibles, ni en recipientes cerrados como tanques, tambores o tuberías, a menos que estén preparados correctamente de acuerdo con la norma AWS F4.1 y AWS A6.0 (vea las normas de seguridad).
- Siempre mire que no haya fuego y mantenga un extinguidor de fuego cerca.
- Lea y entienda las Hojas de datos del material (SDS) y las instrucciones del fabricante relacionadas con los adhesivos, metales, consumibles, recubrimientos, limpiadores, refrigerantes, desengrasadores, fundentes y metales.

EL AMONTONAMIENTO DE GAS puede enfermarle o matarle.



- Cierre el suministro de gas comprimido cuando no lo use.
- Siempre dé ventilación a espacios cerrados o use un respirador aprobado que reemplaza el aire.

LOS RAYOS DEL ARCO pueden quemar sus ojos y piel.



Los rayos del arco de un proceso de suelda producen un calor intenso y rayos ultravioletas fuertes que pueden quemar los ojos y la piel. Las chispas se escapan de la soldadura.

- Use una careta para soldar aprobada equipada con un filtro de protección apropiado para proteger su cara y ojos de los rayos del arco y de las chispas mientras esté soldando o mirando. (véase los estándares de seguridad ANSI Z49.1 y Z87.1).
- Use anteojos de seguridad aprobados que tengan protección lateral.
- Use pantallas de protección o barreras para proteger a otros del destello, reflejos y chispas, alerte a otros que no miren el arco.
- Use protección para el cuerpo hecha de cuero o de prendas resistentes a las llamas (FRC). Entre la protección para el cuerpo se incluye la ropa sin aceite, como guantes de cuero, una camisa gruesa, pantalones sin vuelta, calzado alto y una gorra.

PARTES CALIENTES puedan causar quemaduras severas.



- Permita que la antorcha se enfríe antes de tocarla.
- No toque metal caliente.
- Proteja a otros del contacto con el metal caliente.

EL RUIDO puede trastornar su oído.



Ruido proveniente de algunos procesos o equipo puede dañar el oído.

- Chequee los límites del nivel del ruido si exceden aquellos especificados por OSHA.
- Use tapas para los oídos o cubiertas para los oídos si el nivel del ruido es demasiado alto.
- Advierta a otros que estén cerca acerca del peligro del ruido.

EL ALAMBRE de SOLDAR puede causarle heridas.



- Mantenga las manos y el cuerpo lejos del tubo de contacto de la antorcha cuando se haya presionado el gatillo.

LEER INSTRUCCIONES.

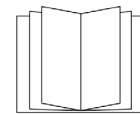

- Lea y siga cuidadosamente las instrucciones contenidas en todas las etiquetas y en el Manual del usuario antes de instalar, utilizar o realizar tareas de mantenimiento en la unidad. Lea la información de seguridad incluida en la primera parte del manual y en cada sección.
- Utilice únicamente piezas de reemplazo legítimas del fabricante.
- Los trabajos de instalación y mantenimiento deben ser ejecutados de acuerdo con las instrucciones del manual del usuario, las normas del sector y los códigos nacionales, estatales y locales.

3-3 Advertencias de la Proposición 65 del estado de California



ADVERTENCIA: Este producto puede exponerlo a químicos, incluso plomo, que el estado de California conoce como causantes de cáncer, defectos de nacimiento u otros daños reproductivos.

Para obtener más información, acceda a www.P65Warnings.ca.gov.

3-4 Estándares principales de seguridad

Safety in Welding, Cutting, and Allied Processes, American Welding Society standard ANSI Standard Z49.1. Website: www.aws.org.

Safe Practice For Occupational And Educational Eye And Face Protection, ANSI Standard Z87.1, from American National Standards Institute. Website: www.ansi.org.

Safe Practices for the Preparation of Containers and Piping for Welding and Cutting, American Welding Society Standard AWS F4.1 from Global Engineering Documents. Website: www.aws.org.

National Electrical Code, NFPA Standard 70 from National Fire Protection Association. Website: www.nfpa.org.

Safe Handling of Compressed Gases in Cylinders, CGA Pamphlet P-1 from Compressed Gas Association. Website: www.cganet.com.

Safety in Welding, Cutting, and Allied Processes, CSA Standard W117.2 from Canadian Standards Association. Website: www.csagroup.org.

Standard for Fire Prevention During Welding, Cutting, and Other Hot Work, NFPA Standard 51B from National Fire Protection Association. Website: www.nfpa.org.

OSHA, Occupational Safety and Health Standards for General Industry, Title 29, Code of Federal Regulations (CFR), Part 1910.177 Subpart N, Part 1910 Subpart Q, and Part 1926, Subpart J. Website: www.osha.gov.

SR7_spa 2022-01

3-5 Información sobre los campos electromagnéticos (EMF)

La corriente que fluye a través de un conductor genera campos eléctricos y magnéticos (EMF) localizados. La corriente del arco de soldadura (y otras técnicas afines como la soldadura por puntos, el ranurado, el corte por plasma y el calentamiento por inducción) genera un campo EMF alrededor del circuito de soldadura. Los campos EMF pueden interferir con algunos dispositivos médicos implantados como, por ejemplo, los marcapasos. Por lo tanto, se deben tomar medidas de protección para las personas que utilizan estos implantes médicos. Por ejemplo, aplique restricciones al acceso de personas que pasan por las cercanías o realice evaluaciones de riesgo individuales para los soldadores. Todos los soldadores deben seguir los procedimientos que se indican a continuación con el objeto de minimizar la exposición a los campos EMF generados por el circuito de soldadura:

1. Mantenga los cables juntos retorciéndolos entre sí o uniéndolos mediante cintas o una cubierta para cables.
2. No ubique su cuerpo entre los cables de soldadura. Disponga los cables a un lado y apártelos del operario.

3. No enrolle ni cuelgue los cables sobre su cuerpo.
4. Mantenga la cabeza y el tronco tan apartados del equipo del circuito de soldadura como le sea posible.
5. Conecte la pinza de masa en la pieza lo más cerca posible de la soldadura.
6. No trabaje cerca de la fuente de alimentación para soldadura, ni se siente o recueste sobre ella.
7. No suelde mientras transporta la fuente de alimentación o el alimentador de alambre.

Acerca de los aparatos médicos implantados:

Las personas que usen aparatos médico implantados deben consultar con su médico y el fabricante del aparato antes de llevar a cabo o acercarse a soldadura de arco, soldadura de punto, ranurar, hacer corte por plasma, u operaciones de calentamiento por inducción. Si su doctor lo permite, entonces siga los procedimientos de arriba.

ADDITIONAL INFORMATION

Introduction

Thank you for choosing Bernard. The product you have purchased has been carefully assembled and factory tested prior to shipment. Should you experience problems with installation or performance, please refer to the “Troubleshooting Guide” in this manual.

Before installing, compare the equipment received against the invoice to verify that the shipment is complete and undamaged. It is the responsibility of the purchaser to file all claims of damage or loss that may have occurred during transit with the carrier.

The manual contains general information on the operation of this Bernard product. Before installing or operating any equipment, read and understand the information and safety precautions presented in this manual. Also, note the various data plates, labels, and tags attached to the product.

While every precaution has been taken to assure the accuracy of this manual, Bernard assumes no responsibility for errors or omissions. Bernard assumes no liability for damages resulting from the use of the information contained herein. Bernard shall have no liability to the buyer for consequential damages or be liable to the in tort for any negligent manufacture of the goods or for the omissions of any warning therefrom.

Commercial Warranty

Product is warranted to be free from defects in material and workmanship for 1 year after the sale by an authorized Buyer. Straight handles, straight handle switches and straight rear strain reliefs are covered by a lifetime warranty.

Bernard reserves the right to repair, replace or refund the purchase price of non-conforming product. Product found not defective will be returned to the Buyer after notification by Customer Service.

Bernard makes no other warranty of any kind, expressed or implied, including, but not limited to the warranties of merchantability or fitness for any purpose. Bernard shall not be liable under any circumstances to Buyer, or to any person who shall purchase from Buyer, for damages of any kind. Including, but not limited to any, direct, indirect incidental or consequential damages or loss of production or loss of profits resulting from any cause whatsoever, including, but not limited to, any delay, act, error or omission of Bernard.

Genuine Bernard parts must be used for safety and performance reasons or the warranty becomes invalid. Warranty shall not apply if accident, abuse, or misuse damages a product, or if a product is modified in any way except by authorized Bernard personnel.

SECTION 4 — INSTALLATION

4-1 General Description

The Bernard PipeWorx MIG Gun is designed primarily for processing mild steel electrode under GMAW (Gas Metal Arc Welding), MIG (Metal Inert Gas), MAG (Metal Active Gas), FCAW (Flux Cored Arc Welding), and MOG (Metal without Gas).

The PipeWorx MIG Gun provides rapid neck interchangeability, typically during production processes. Neck may also be positioned on line within a 360 degree rotation. This position allows for movements between standard horizontal welding, overhead, and hard-to-reach side angles. The neck includes an optional jump liner system that effectively reduces costs associated with one-piece liner systems.

Bernard is concerned about your higher productivity.

The PipeWorx MIG Gun meets or exceeds NEMA (National Electrical Manufacturer's Association) EW3 requirements for guns used in a wide variety of applications including aluminum, silicone bronze, and hard facing alloys to name a few. With Bernard's flexibility, many applications can be accommodated with field installed options increasing performance and maneuverability. Bernard® MIG guns General.

4-2 Installation

1. Your gun has been shipped with a specific feeder connector, neck, and sized for electrode as per the part number indicated on its package. Please inspect the received gun against this part number for accuracy.
2. Turn off power prior to any installation.
3. Fully extend gun and cable. Press liner fully into power pin.
4. Safely expose approximately 2" (51 mm) of electrode beyond feeder or adaptor block.

5. **Power Pin**

Connect the power pin of the direct plug gun by sliding the electrode into the liner and the power fitting into the drive housing of the feeder. Fully seat the unit in position and tighten into place as designated in the manufacturer's instructions. On initial installations, a thin film of silicone lubricant will aid installation and prevent o-ring damage.

Attach control lead wires to the appropriate plug, terminals, or lead kit. Plug or wire into the control circuit of the feeder as designated in manufacturer's instructions.

If a gas hose is provided, connect to the feeder's solenoid circuit to deliver shielding gas to the arc. If no gas hose is provided, gas is delivered through the power pin. Refer to the manufacturer's instructions for proper gas connection at the feeder block or solenoid.

6. Remove nozzle from head assembly.
7. Pull contact tip from head/gas diffuser. An unobstructed electrode path has now been established.
8. Safely feed electrode through the gun and approximately 1" (25 mm) beyond head/gas diffuser.
9. Reinstall the contact tip over the electrode and lock into position by reinstalling the nozzle.

NOTICE

Welding current and duty cycle shall not exceed published specification of this product. If such conditions exist, product life and performance will be reduced.

4-3 Helpful Operating Tips

Nozzles:

1. If anti-spatter is used, do not coat nozzle insulator as this may degrade insulating material.
2. Nozzle should be cleaned as often as possible. Spatter buildup can often lead to poor gas shielding or short circuiting between the contact tip and the nozzle.
3. Spatter should be removed with the proper tools designed for spatter removal.
4. In high temperature welding applications, heavy duty consumables are recommended.

Contact Tips, Gas Diffusers:

1. Contact tips may be removed and rotated in gas diffuser, providing an additional wear surface and extending the service life of the product.
2. Inspect nozzle for spatter adhesion, blocked gas ports, and carburized contact surfaces. Clean as often as possible.
3. If anti-spatter is used, periodically check gas ports for blockage.

Feeder:

1. Check drive rolls for wear; be sure drive rolls and guide tubes are clean and free of debris. Do not overtighten drive rolls; set as per manufacturer's specifications.
2. Use clean, non-corroded electrode.
3. When installing or replacing electrode, you may: remove burrs from end of electrode, remove head/gas diffuser and contact tip, and/or straighten the first few inches of electrode.
4. When using dual shield electrode, periodically check gas ports in gas diffuser for clogging caused by flux from within the electrode.

Cable:

1. Periodically check torques of neck and end fittings. Loose fittings can cause overheating and premature failure of the gun.
2. Sharp bends and loops in the cable should be avoided. Often the best solution is to suspend the wire feeder from a boom or trolley, thus eliminating a large number of bends and keeping the cable clear of hot weldments.
3. Do not immerse liner into solvents for cleaning; the liner may be periodically blown out with compressed air.
4. Avoid rough surfaces and sharp edges that can cause tears and nicks in cable jacket which can cause premature failure.
5. Periodically check all cables and ground connections.
6. Use anti-seize on all threaded connections.

End User Stocking Recommendations:

Nozzles	5 for every 1 gun in service
Contact Tips	30 for every 1 gun in service
Gas Diffusers	4 for every 1 gun in service
Triggers	1 for every 10 guns in service
Necks	1 for every 20 guns in service
Handle Kits	1 for every 20 guns in service
Replacement Cables	1 for every 20 guns in service
Strain Relief Kits	1 for every 20 guns in service
Adaptor Kits	Order as Necessary
Power Pin Kits	Order as Necessary

These stocking recommendations are only initial guidelines based on an 80 hour work period. You should work closely with your distributor to tailor a stocking program that suits your specific needs. Results will vary.

SECTION 5 — MAINTENANCE AND REPAIR

See page 10 for the parts list.



Disconnect gun from equipment, allow to cool, and remove electrode from liner before servicing.

FIGURE #1

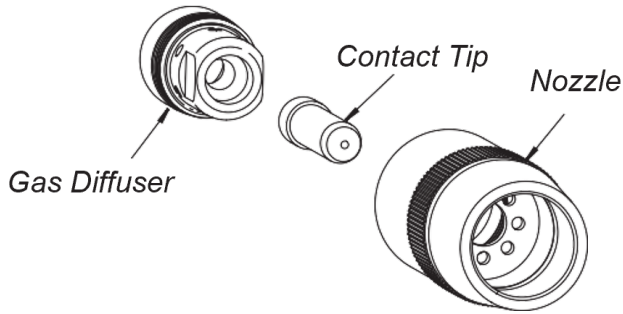

5-1 Nozzle

A. Removal

Threaded fit nozzle can be removed by turning in a counter-clockwise direction.

B. Service

Inspect nozzle for cracks and degradation of insulation. Clean the nozzle as often as possible to prevent spatter build-up which can lead to poor gas shielding or short circuiting. Replace the nozzle when loose, worn, or producing erratic gas shield.

C. Installation

Replace threaded fit nozzle by threading in a clockwise direction. Nozzle body is used to secure contact tip.

5-2 Contact Tip

Bernard has designed Centerfire™ Contact Tips to allow rapid installation and adjustment.

A. Removal

Cut electrode and remove all burrs. Remove threaded fit nozzle by turning in a counterclockwise direction. Pull the Centerfire Contact Tip from gas diffuser.

B. Service

To extend contact tip life, reface front of contact tip and clean the bore. Contact tips may be rotated in gas diffuser/ head socket providing additional wear surface and extending the service life of the product.

C. Installation

Replacement is accomplished by cutting electrode and removing all burrs. Slide contact tip over electrode into gas diffuser and replace threaded fit nozzle by threading in a clockwise direction. Nozzle body is used to secure contact tip.

5-3 Gas Diffuser

A. Removal

The head may be removed with an appropriate wrench in a counterclockwise rotation.

B. Service

Inspect head for spatter, blocked gas ports, and carburized surfaces. Clean as often as possible. Replace with new gas diffuser when wear prevents engagement of contact tip or nozzle.

C. Installation

Firmly secure gas diffuser with an appropriate wrench in a clockwise rotation, torque to 144 in-lbs. Be sure insulator cap is in place as shown in figure #1.

5-4 Neck

A. Removal

Grasp lock nut and rotate counterclockwise, rotation will free neck from end fitting.

B. Installation

Before installing, inspect neck and end fitting for debris, clean if necessary. Install neck in reverse order, torque to 38 in-lbs. NOTE: Refer to Jump Liner literature for liner cut off sizes (if used).

5-5 Jump liner (Optional)

A. Removal

Remove nozzle, gas diffuser and neck. Remove used jump liner from the back end of neck.

B. Service

Inspect for excessive wear and debris on the inside diameter. Do not dip jump liner in solvents for cleaning. Jump liners may be periodically blown out with shop air. Replace with new jump liner when excessive wear or debris produces poor electrode feed.

C. Installation

Insert jump liner making sure the liner stop is fully seated at the back of the neck. Take the tapered end of the neck and insert into end fitting of the gun handle. Install the neck. Trim and deburr the liner past the nozzle end of the neck.

Install gas diffuser and nozzle.

5-6 Handle

FIGURE #2

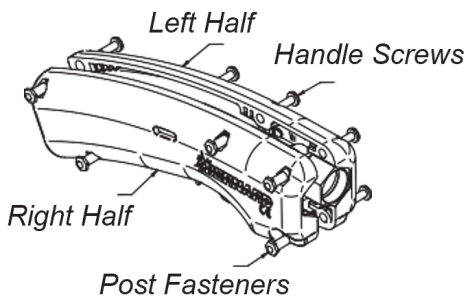

A. Removal

Remove screws, post fasteners. Separate and remove handle halves.

B. Service

Inspect for cracks, deformation of hex areas, debris, holes, loose or missing threaded inserts, excessive wear, exterior heat deformation, and warpage. If any of the above conditions exist, replace with new handle or clean all surfaces with mild detergent and reinstall. Test switch for continuity. Clean any debris from trigger, if necessary, replace with new trigger handle assembly.

C. Installation

Position cable in handle half. Pressing lead wire terminal fully into terminals of switch. Position remaining handle half so leads are not pinched and movement of the trigger is not impaired. Post fasteners, and screws; torque to 10 in-lbs (1.1 Nm).

5-7 Cable

A. Inspection

Replace the cable assembly if the following conditions are evident on the exterior of the cable: cuts and/or abrasions in cable jacketing exposing copper stranding, abrupt kinking of cable causing abnormal heating in area of bend, loss of control circuit function as verified through continuity tests, slippage of insulating jacket exposing copper stranding, or crushed cable.

B. Replacement

Using a replacement cable, install the terminated cable end to the adapter block. It will be necessary to install or confirm that the flexible strain relief and cap is in place before preparation (See Figure 3).

FIGURE #3

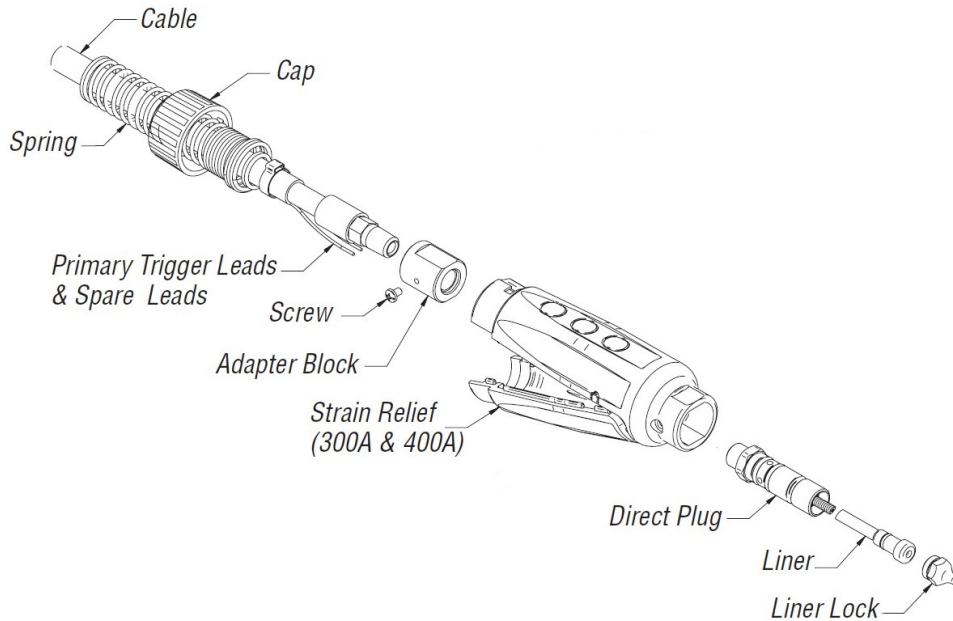

Torque the end fitting into the adapter block to 17 ft-lbs (23 Nm). Strip the appropriate control leads 1/4" (6.4 mm) and crimp to appropriate butt connections of trigger leads. Finalize installation.

C. Repair

There is no authorized repair of welding cable due to product liability. Control leads may be repaired by splicing high temperature 18 AWG lead wire with nylon coated butt connectors, or spare leads can be used.

5-8 Liners

A. Removal

Remove nozzle and gas diffuser

Guns with jump liner: Remove neck. Lay cable straight. Grasp liner lock which protrudes from power pin (some direct plugs may require removal of additional components to access the liner lock) and remove from cable assembly.

B. Service

Inspect for excessive wear and debris on the inside diameter. Do not dip liner in solvents for cleaning. Liner may be periodically blown out with shop air. Replace with new liner when excessive wear or debris produces poor electrode feed.

C. Installation

Insert liner into power pin with cable laying straight. Continue until liner lock is fully seated into power pin. A twisting motion may be necessary to seat o-ring (some direct plugs may require installation of additional components to secure liner).

Making sure cable is straight, trim and deburr liner beyond end of neck to 9/16" (14.3 mm)

When using Jump Liner: Trim and deburr liner with 1/4" (6.4 mm) extending beyond the gun handle. Install neck.

Install gas diffuser and nozzle.

5-9 Rigid Strain Relief

A. Removal

Using a counterclockwise motion, unseat cap and sleeve assembly from rigid strain relief. Remove screw securing strain relief to adapter block.

B. Service

Inspect all components for cracks, debris, excessive wear and breakage. Replace with new components if safety or performance of product is compromised.

C. Installation

Align flats in rigid strain relief with flats on adapter block. Slide strain relief onto adapter block and install screw.

Torque screw to 12 in-lbs (1.4 Nm). Using the arrows on the cap to align with mating grooves, slide the cap and sleeve assembly toward the rigid strain relief until seated, and turn clockwise until engaging snap is felt.

5-10 Miller Power Pins

A. Removal

Remove the power pin tip that retains the liner from the power pin with the appropriate wrench. Remove liner and rigid strain relief from gun assembly. Position control lead wires as necessary as not to damage them. Remove power pin from adapter block using appropriate wrenches in a counterclockwise rotation (See Figure 3).

FIGURE #3

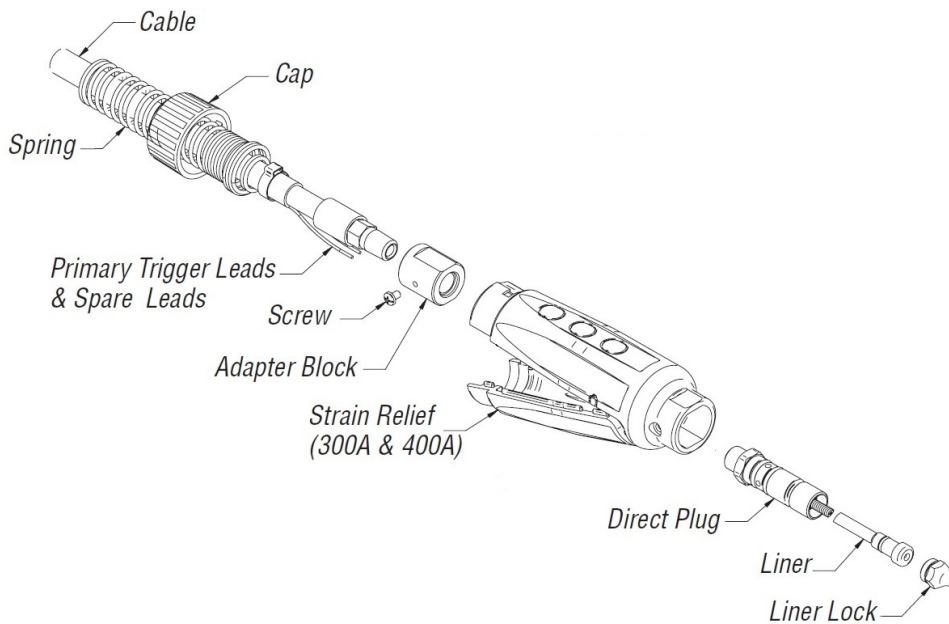

B. Service

Test lead wires for continuity when trigger is engaged. Lubricate o-rings with silicone lubricant. Inspect all components for cracks, debris, excessive wear, and breakage. Replace with new components if safety or performance of product is compromised.

C. Installation

Assemble power pin onto adapter block in a clockwise rotation using appropriate wrenches. Torque to 13 ft-lbs (17.6 Nm)
Install liner. Install power pin tip and tighten to retain liner assembly (See Figure 3).

SECTION 6 — PARTS LIST

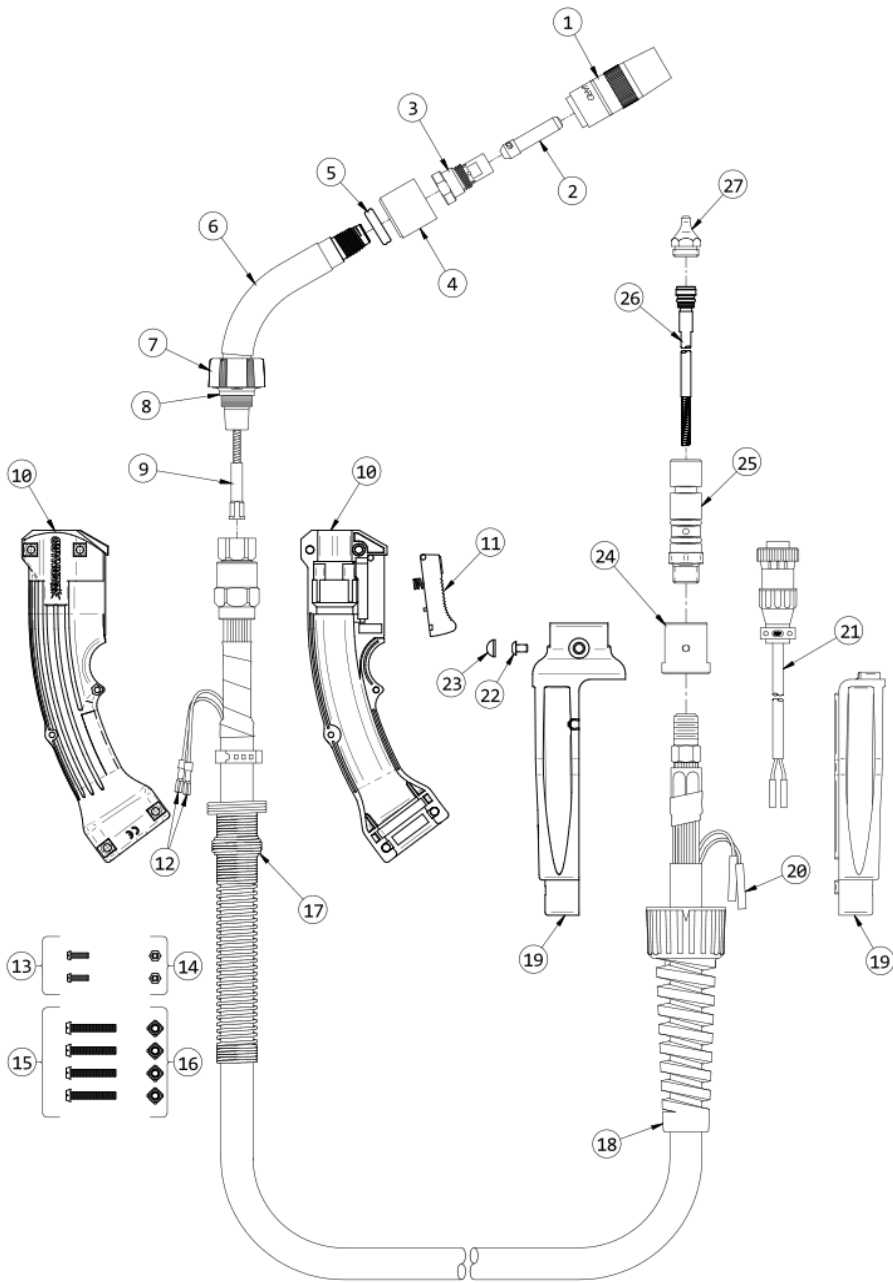

ITEM	Part #	Description
1	NS-5818C	Nozzle
2	T-045	Contact Tip
3	DS-1	Diffuser
4	4523R	Cap
5	1840057-2P	Q-Nut Insulator, Front
6	QT2-60	Neck (Includes neck and items #5, #7, #8)
7	1840057-1	Q-Neck Cover
8	1840031	Q-Neck Insulator, Rear
9	QJL-3545	Jump Liner
10	1880219	Handle Kit (Includes handle and items #13, 14, 15, 16)
11	177488H	Trigger
12	177271H	Terminal
13	2280044P	Screw
14	2030029P	Nut
15	203296-005P	Screw
16	177272H	Nut
17	M169700-12	Handle Spring
18	2520033	Strain Relief
19	2520066	Strain Relief Set
20	4932P	Butt Connector
21	GN2021	Electrical Connection
22	2280056P	Screw
23	1620003P	Screw Cover
24	1010027	Adaptor Block
25	2200101	Power Pin Assy.
26	LD3A-15	Liner
27	2200135	Power Pin Tip

SECTION 7 — TROUBLESHOOTING

7-1 Troubleshooting Table

PROBLEM	POSSIBLE CAUSE	CORRECTIVE ACTION
1. Electrode does not feed.	<ol style="list-style-type: none"> 1. Feeder relay. 2. Broken control lead. 3. Poor adaptor connection. 4. Improper / worn drive roll. 5. Drive roll tension misadjusted. 6. Burn back to contact tip. 7. Wrong size liner. 8. Buildup inside of liner. 	<ol style="list-style-type: none"> 1. Consult feeder manufacturer. 2. a. Test and connect spare control lead. b. Install new cable. 3. Test and replace leads and/or contact pins. 4. Replace. 5. Replace with proper size. 6. See 'Contact tip burn back'. 7. Replace with correct size. 8. Replace liner, check condition of electrode.
2. Contact tip burn back.	<ol style="list-style-type: none"> 1. Improper voltage and/or wire feed speed. 2. Erratic wire feeding. 3. Improper tip stickout. 4. Improper electrode stickout. 5. Faulty ground. 	<ol style="list-style-type: none"> 1. Set parameters. 2. See 'Erratic wire feeding'. 3. Adjust nozzle / tip relationship. 4. Adjust gun to base metal relationship. 5. Repair all cables and connections.
3. Contact Tip disengages from head.	<ol style="list-style-type: none"> 1. Worn gas diffuser/retaining head. 2. Improper contact tip installation. 3. Extreme heat or duty cycle. 	<ol style="list-style-type: none"> 1. Replace contact tip and/or gas diffuser. 2. Install as per Maintenance & Repair (Section 5). 3. Replace with heavy duty consumables. See appropriate Spec Sheet for details.
4. Short contact tip life.	<ol style="list-style-type: none"> 1. Contact tip size 2. Electrode eroding contact tip. 3. Exceeding duty cycle. 	<ol style="list-style-type: none"> 1. Replace with proper size. 2. Inspect and/or change drive rolls. 3. Replace with properly rated Bernard MIG Gun.
5. Erratic arc.	<ol style="list-style-type: none"> 1. Worn contact tip. 2. Buildup inside of liner. 3. Wrong contact tip size. 4. Not enough bend in neck. 	<ol style="list-style-type: none"> 1. Replace. 2. Replace liner, check condition of electrode. 3. Replace with correct contact tip size. 4. Replace with 45° or 60° neck.
6. Erratic wire feeding.	<ol style="list-style-type: none"> 1. Buildup inside of liner. 2. Wrong size liner. 3. Improper drive roll size. 4. Worn drive roll. 5. Improper guide tube relationship. 6. Improper wire guide diameter. 7. Gaps at liner junctions. 8. Feeder malfunction. 9. Contact tip. 	<ol style="list-style-type: none"> 1. Replace liner, check condition of electrode. 2. Replace with new liner of proper size. 3. Replace with proper size drive roll. 4. a. Replace with new drive roll. b. Stone edge of groove on drive roll. 5. a. Adjust / replace guide as close to drive rolls as possible. b. Eliminate all gaps in electrode path. 6. Replace with proper guide diameter. 7. a. Replace with new liner trimmed as per Maintenance & Repair (Section 5). b. Replace guide tube / liner trimming as close to mating component as possible. 8. Consult feeder manufacturer. 9. Inspect and replace.*
7. Extreme spatter.	<ol style="list-style-type: none"> 1. Improper machine parameters. 2. Improper contact tip installation. 3. Improper shielding. 4. Contaminated wire or workpiece. 	<ol style="list-style-type: none"> 1. Adjust parameters. 2. Adjust nozzle / contact tip relationship. 3. a. Verify shielding gas coverage. b. Verify gas mixture. 4. Clean wire and workpiece.

8. Porosity in weld.	<ol style="list-style-type: none"> 1. Insulator worn. 2. Gas diffuser damaged 3. Extreme heat or duty cycle. 4. Solenoid faulty. 5. No gas. 6. Flow improperly set. 7. Gas ports plugged. 8. Ruptured gas hose. 9. Control circuit loss. 10. Worn, cut or missing o-rings. 11. Loose fittings. 	<ol style="list-style-type: none"> 1. Replace nozzle / insulator. 2. Replace gas diffuser. 3. Replace with heavy duty consumables. 4. Replace solenoid. 5. <ol style="list-style-type: none"> a. Install full tanks. b. Check supply. c. Check for hose leaks. 6. Adjust flow. 7. <ol style="list-style-type: none"> a. Clean or replace gas diffuser. b. Clean nozzle. 8. Repair or replace cable or line. 9. See 'Electrode does not feed'. 10. Replace o-rings. 11. Tighten gun and cable connections to specified torque. See Maintenance & Repair (Section 5).
9. Gun running hot.	<ol style="list-style-type: none"> 1. Exceeding duty cycle. 2. Loose or poor power connection. 	<ol style="list-style-type: none"> 1. <ol style="list-style-type: none"> a. Replace with properly rated Bernard MIG Gun. b. Decrease parameters to within gun rating. 2. <ol style="list-style-type: none"> a. Clean, tighten or replace cable grounding connection. b. Tighten gun and cable connections to specified torque. See Maintenance & Repair (Section 5).
10. Liner is discolored full length.	<ol style="list-style-type: none"> 1. Short circuit to electrode. 2. Broken copper stranding in power cable. 	<ol style="list-style-type: none"> 1. Isolate electrode reel from feeder and drive block. Consult feeder manufacturer's manual. 2. Replace MIG gun.
11. Sporadic feeding of aluminum electrode.	<ol style="list-style-type: none"> 1. Contact tip galling. 2. Synthetic liner melting. 3. Wire deformed by feeder rolls. 	<ol style="list-style-type: none"> 1. Inspect and replace.* 2. <ol style="list-style-type: none"> a. Replace liner. b. Replace with composite liner. c. Replace with Q-Gun neck and jump liner. 3. Adjust drive rolls as per feeder manufacturer's manual.

**In some cases with aluminum and mild steels, it may be necessary to use a contact tip with either a larger or smaller bore size.*